



2024-2025 Rules & Guidelines

The objectives of the Texas 4-H Horse Program include providing means for 4-H members to:

- 1) Acquire horsemanship and horse training skills.
- 2) Gain knowledge concerning science related subjects including horse production, management, training, evaluation and use.
- 3) Prepare for citizenship responsibilities and community service.
- 4) Develop leadership, initiative, self-reliance, sportsmanship, and other desirable life traits.

4-H Horse Point Show Dates for 2024-2025

November 16, 2024

January 11, 2025

February 15, 2025

April 19, 2025

4-H Horse Fundraiser Dates for 202-2025

Jingle Bell Fundraiser - December 21, 2024

Gallopalooza Fundraiser (Rain Out) - May 31, 2025

The Brazoria County 4-H Horse Advisory Committee (HAC) reserves to its leaders the final right to interpret all rules to settle and determine all matters, questions and differences in regard to, or otherwise arising out of, aligned with, or incident to the Brazoria County 4-H Horse Shows. The HAC reserves the right to pass judgment on such rules. If necessary, the HAC will give an on-the-spot decision that shall be accepted as final.

If you see an issue with the on-the-spot judgment you can protest such a decision. If for some reason you would like to protest the judgment you can see page 9 for more information.

The 4-H Horse Point Shows will be conducted according to the official rules of the 2023 edition of the Texas 4-H Horse Show Rules and Regulations, plus additional rules outlined here. It is the responsibility of the 4-H member and their parents to become familiar with the rules and to abide by them.

Horse Project Participation

To be considered a member of the Brazoria County 4-H Horse Project, individuals must meet the following requirements:

1. **Become a member of Brazoria County 4-H:** Members must have completed a 4-H membership profile on 4-H Online. Link to 4-H Online: <https://v2.4honline.com/#/user/sign-in>
2. **Be in good standing with their Brazoria County 4-H Club:** To be eligible to participate in a 4-H Horse Point Show or other 4-H contests/events, each 4-H'er must be in good standing with his/her 4-H club. This will be determined by the County Extension Agent before each show.
3. **Galveston County 4-H Members:** Members in good standing of Galveston County 4-H are welcomed to participate in Brazoria County Horse Point Shows. Galveston County 4-H members will show alongside Brazoria County 4-H members and are required to fulfill all requirements to be eligible for end-of-year awards.
4. **Fort Bend County 4-H Members:** Members in good standing of Galveston County 4-H are welcomed to participate in Brazoria County Horse Point Shows. Galveston County 4-H members will show alongside Brazoria County 4-H members and are required to fulfill all requirements to be eligible for end-of-year awards.

4-H Horse Project Age Divisions

Members must compete in their appropriate age categories based on grade as of August 31, 2023.

Clover Kids: Kindergarten, Grades 1 and 2

Junior/Intermediate: Grades 3, 4, 5, 6, 7, and 8

Senior: Grades 9, 10, 11, and 12

Please Note: Due to a Texas 4-H rule, Clover Kids are NOT eligible to show at our 4-H Horse Point Shows, including Performance and Speed classes. However, they are able to participate in non-riding events. They can also still be members in the Brazoria County 4-H Horse Program, learn from other members, and participate in non-riding horse activities.

2024-2025 RULES UPDATES (as of 9/18/2024)

1. Horse Project Participation now states that Fort Bend County 4-H members can participate in Brazoria County Point Shows and are eligible for end-of-year awards.
2. Horse Ownership/Lease Requirement has been reinstated.
3. Horse Validation for Horse Point shows has been reinstated.
4. Scholastic Eligibility forms are no longer required to be turned in for shows.
5. Coggins test must be submitted with validation.
6. Show registrations are now due the Wednesday before the show by 4 PM.
7. Invitational and Performance Shows start at 9 am.
8. Stick horse books now close at 12:30 pm and the show will start at the conclusion of the Performance Show.
9. Concerns must also be emailed or presented in writing to the County Extension Office within five days after the show.
10. No two 4-H members may ride the same horse in the same class. Exceptions to this rule may be requested based on the Hardship Clause (see page 15).
11. Tank tops should not be visible during the Horse Show.
12. During Performance Classes, riders must wear a long-sleeved collared shirt, also known as a performance shirt along with a belt, and either a hat or helmet. During Speed Classes, riders must wear a long-sleeved collared shirt, belt, heeled boots. Outerwear can be worn during speed events runs.
13. Payment of \$50 to be paid to judge per hour after 12 PM has been removed.
14. Updates have been made to *15. In case of death, injury, or illness of 4-H members Primary Project Horse*: has been updated. See page 10 and 11.
15. Complaints must be emailed or presented in writing to the County Extension Office five (5) days after the point show.
16. Novice Western Pleasure will be held for beginning riders only. End-of-Year 1st place winners in Novice and Walk Trot must advance to a higher level pleasure class the following year.
17. The flag judge may not be a parent/guardian or family member of the contestant.
18. For speed events, riders will have 3 minutes to complete their run or they will receive a “no time” for the class.
19. Exhibitions will be run for up to 45 minutes for Cloverleaf Barrels, up to 30 minutes for Pole Bending, and 15 minutes for Straights Race.
20. 4-H Horse/rider team must participate in three of the four performance shows to be eligible for End-of-Year performance awards.
21. 4-H Horse/rider team must participate in three of the four speed shows to be eligible for End-of-Year speed awards.
22. Scholarship application has been updated. See page 15 and county 4-H website for more information.

4-H Horse Point Show Requirements

1. **Horse Ownership/Lease Requirement:** Horses must be owned or leased 30 days prior to the first points show the horse will participate in. Documentation of this will need to be provided with horse validation (such as registration papers, bill of sale and/or lease agreement).
2. **Horse Validation:** The Horse Validation process for the horse that will be shown at a 4-H Horse Point Show must be completed 30 days prior to the first points show the 4-H member will participate in. It is encouraged that members validate any eligible horses that may serve as secondary horses in the case of unfortunate illness or death of the primary project horse . *Links for validation are inserted here.* Validation will include the three pictures of the horse (front, left side, and right side) along with the following:
 - a. **For Registered Horses – registration papers front and back showing current owner of the horse**
 - i. **If current owner is not listed on the registration papers, a Bill of Sale showing current owner must be provided to demonstrate ownership of the horse**
 - b. **For Grade Horses – Bill of Sale showing current owner of the horse**
 - c. **For horses that are leased, the current lease agreement must also be submitted as part of the validation process**
3. **Scholastic Eligibility (House Bill 72 “No Pass/No Play”):** Brazoria County 4-H Horse Point Shows are no longer requiring eligibility forms to be turned in for shows.
4. **Validation Requirements only for District and State 4-H Horse shows.** Each horse that is to be entered in the District and/or State 4-H Horse Shows (including any possible substitution horses and futurity projects) must meet the validation requirements set forth in the current year’s Texas 4-H Horse Show Rules and Regulations.
5. **Coggins Test:** This is a Texas Animal Health Commission ruling and is not negotiable. Effective January 1, 1997, all equines, regardless of origin, entering any show, fair and/ or exhibition must have a negative test for EIA conducted within the previous 12 months (Coggins or AGID test). A current copy of these test results will need to be submitted **with validation**.
6. **Other Documents Required by the First 4-H Point Show:** During the 4-H Online enrollment process, members should verify that they have completed the following:
 - a. Acknowledgment of Rules
 - b. Minors Release Acknowledgement and Consent

4-H Horse Point Show Registration, Fees, and Classes

1. **Show Registration Entries:** Show entry will be due by **Wednesday** at 4pm the week of the 4-H Horse Point Show via the online web-form found on the Brazoria County 4-H website. Any entry after **Wednesday** at 4pm, will be assessed a \$40 late fee. Fully signed paper entries with both participant and parent signatures can also be submitted to the 4-H Office by the deadline in lieu of submitting the web-form. Registration forms are found on page 7 and 8 of these rules.
2. **Office Fee:** There will be a \$10 office fee per contestant at each show.

3. **Book Close and Show Times:**
 - a. **Invitational and Performance:** Books Close at 8 am – Show Start at 9:00 am.
 - b. **Stick Horse:** Books close at 12:30pm and the show will start at the conclusion of the Performance Show.
 - c. **Invitational Timed and Speed:** Books Close at 2pm, will not start before 2:30pm.
4. **Class Fees:**
 - a. **Qualifying Classes:** Flat fee of \$40 per horse/rider team
 - b. **Invitational Classes:** \$10 per class
 - c. **Special Needs:** \$10 per class
 - d. **Drill/ Quad:** \$20 per Team for Quad & \$50 per Team for Drill
 - e. **Exhibitions:** (To be run before each qualifying event) \$5 each
 - f. **Stick Horse Events:** \$10 each
5. **Classes:**
 - a. **Performance Qualifying Classes**
 - Showmanship
 - Western Pleasure
 - Junior/Intermediate (Walk/Trot/Lope) or Novice (Walk/Trot) (can only select 1 class)
 - Novice riders must be eligible based on qualifications detailed below in “4-H Horse Point Show General Rules and Regulations” on page 13.
 - Western Horsemanship
 - b. **Invitational Judged Classes**
 - Yearling Halter
 - Halter Mares
 - Halter Geldings
 - Stock Horse Pleasure
 - Reining
 - Trail
 - Hunter Under Saddle
 - Hunt Seat Equitation
 - Hunter Hack
 - c. **Invitational Timed Classes**
 - Goat Tying
 - Stakes Race
 - d. **Speed Qualifying Classes**
 - Cloverleaf Barrels
 - Pole Bending
 - Straight-away Barrels
 - e. **Special Needs Classes**
 - Halter
 - Western Pleasure
 - Barrels
 - f. **Clover Kid Stick Horse Classes**
 - Stick Horse Goat Ribbon Pulling
 - Stick Horse Cloverleaf Barrels
 - Stick Horse Pole Bending
 - Stick Horse Stakes Race

Brazoria County 4-H Horse Point Show Registration Form

Exhibitor Name: _____	Age Group: Jr./Int. Sr
4-H Club: _____	Point Show: 1 st 2 nd 3 rd 4 th
Club Leader: _____	Date: _____

Invitational Halter: \$10/class

- ___ 1. Yearling Halter
- ___ 2. Halter Gelding
- ___ 3. Halter Mares

Performance Qualifying Classes: \$40 flat fee

- ___ 5. Jr./Int. Halter Showmanship
- ___ 6. Sr. Halter Showmanship
- ___ 7. Novice Western Pleasure
- ___ 8. Jr./Int. Western Pleasure
- ___ 9. Sr. Western Pleasure
- ___ 10. Jr./Int. Western Horsemanship
- ___ 11. Sr. Western Horsemanship

Invitational Judged Classes: (\$10/class)

- ___ 13. Stock Horse Pleasure
- ___ 14. Reining
- ___ 15. Trail
- ___ 16. Hunter Under Saddle
- ___ 17. Hunt Seat Equitation
- ___ 18. Hunter Hack

Invitational Timed Speed: \$10/class

- ___ 19. Goat Tying
- ___ 20. Stakes Race

Speed Qualifying Classes: \$40 flat fee

- ___ 21. Jr./Int. Cloverleaf Barrels
- ___ 22. Sr. Cloverleaf Barrels
- ___ 24. Jr./Int. Pole Bending
- ___ 25. Sr. Pole Bending
- ___ 26. Jr./Int. Straights
- ___ 27. Sr. Straights

Special Needs Classes: \$10/class

- ___ 4. Halter
- ___ 12. Western Pleasure
- ___ 23. Barrels



Drill/Quad: Drill/Precision: \$50/team Quad: \$20/team

Please complete separate entry form for each team.

REMINDERS:

Registration deadline is Wednesday at 4 pm the week of the show. \$40 flat fee will be added to entries after that time and date.

****Checks and Zelle payments for registration fees will only be accepted the day of the show****

Checks must be payable to "*Brazoria County 4-H HAC*"

Zelle payments can be sent to "*bc4hac@gmail.com*"

ENTRY FEES

- Performance Qualifying - \$40 flat fee _____
- Invitational Judged - \$10/class _____
- Invitational Speed - \$10/class _____
- Speed Qualifying - \$40 flat fee _____
- Special Needs Classes - \$5 each _____
- Drill/Precision - \$50/team _____
- Exhibitions - \$5 each _____
- Quad - \$20/team _____
- Late Fee - \$40 _____

By signing this form, you confirm that you have read and understand all Brazoria County 4-H Horse Point Show rules. These rules are set in place by the Brazoria County 4-H Horse Advisory Committee for everyone's safety during the show season. Our objectives are to help the contestants learn and grow with their horse project safely.

Exhibitor Signature: _____

Parents Signature: _____

Date: _____

ONLINE REGISTRATION PREFERRED! <https://agrilife.org/brazoria4h/horse-project/>

Brazoria County 4-H Horse Point Show Registration Form CLOVER KID FORM

Exhibitor Name: _____	Age Group: Clover Kid
4-H Club: _____	Point Show: 1 st 2 nd 3 rd 4 th
Club Leader: _____	Date: _____

Stick Horse Classes: \$10/class or \$30 for all four

- ___ Goat Ribbon Pulling
- ___ Cloverleaf Barrels
- ___ Pole Bending
- ___ Stakes Race

ENTRY FEES

Stick Horse Classes: \$10/class or \$30 for all four

Late Fee: \$40

Office Fee: \$10

\$10
Total: _____



REMINDERS:

Registration deadline is Monday at 4 pm the week of the show. \$40 flat fee will be added to entries after that time and date.

****Checks and Zelle payments for registration fees will only be accepted the day of the show****

Checks must be payable to "Brazoria County 4-H HAC"

Zelle payments can be sent to "bc4hac@gmail.com"

By signing this form, you confirm that you have read and understand all Brazoria County 4-H Horse Point Show rules. These rules are set in place by the Brazoria County 4-H Horse Advisory Committee for everyone's safety during the show season. Our objectives are to help the contestants learn and grow with their horse project safely.

Exhibitor Signature: _____

Parents Signature: _____

Date: _____



Brazoria County 4-H Horse Project Point Show **Quad & Drill Team Registration Form**

Quad & Drill/Precision participants will sign up as a team with one payment instead of each member paying. Include a team name, members of the team, and person responsible for the music below.

Quad Team Entry: \$20/team

Team Name: _____

Team Member (1): _____

Team Member (2): _____

Team Member (3): _____

Team Member (4): _____

Person with music: _____

Drill/Precision Team Entry: \$50/team

Team Name: _____

Team Member (1): _____

Team Member (2): _____

Team Member (3): _____

Team Member (4): _____

Team Member (5): _____

Team Member (6): _____

Team Member (7): _____

Team Member (8): _____

Team Member (9): _____

Team Member (10): _____

Person with music: _____

Please have a way to plug in an aux cord to play your music

4-H Horse Point Show General Rules and Regulations

1. **SAFETY IS OUR UTMOST RESPONSIBILITY!!!** Please bring any concerns regarding safety to the show office immediately so that it can be addressed. **Concerns must also be emailed or presented in writing to the County Extension Office within five days after the show.** Complaints will be reviewed by the County Extension Agent and other parties as deemed appropriate.
2. **No two 4-H members may ride the same horse in the same class. Exceptions to this rule may be requested based on the Hardship Clause (see page 15).**
3. Show attire is determined by the 2023 Texas 4-H Horse Show Rules and Regulations guidelines, with the following exceptions:
 - a. **Tank tops should not be visible during the Horse Show.**
 - b. **During Performance Classes, riders must wear a long-sleeved collared shirt, also known as a performance shirt along with a belt, and either a hat or helmet. During Speed Classes, riders must wear a long-sleeved collared shirt, belt, heeled boots. Outerwear can be worn during speed events runs.**
4. Exhibitors must be fully attired while competing. Wearing a jacket, if the judge allows in cool weather, is permissible during Performance Classes. Fat Baby Boots are discouraged at 4-H Horse Shows.
5. Rules regarding appropriate bits and equipment can be found in the 2023 Texas 4-H Horse Show Rules and Regulations and is summarized in Appendix D. Please review to ensure that all equipment is within these rules. If there are any questions, please ask a 4-H Club Leader or HAC member for clarification prior to showing.
6. While helmets are not required, wearing a helmet is strongly encouraged.
7. The use of small rubber band to aid in holding rider's boots in stirrups is allowed. However, any such aids deemed excessive, deemed by the HAC, will not be allowed at any time. No exhibitor may be tied, buckled, or fastened in the saddle in any manner or by any means. 4-H exhibitors need to be aware that this practice may or may not be allowed at District and State 4-H Horse Shows and train accordingly.
8. During the show, exhibitors, parents, and visitors are not allowed to approach a judge until after all judged events are done and performance overall awards have been announced, with a HAC Member present (if the judge is willing to answer any questions). Approaching a judge during the Point Show to discuss an exhibitor's performance will be considered a protest and will be subject to the rules regarding protests. See Rule #13 (Protests).
9. Small children that are not competing in the 4-H show will not be allowed in the alleyway, the back pens, or the arena.
10. Visitors will be the responsibility of the 4-H family they are with. If a visitor is warned more than once, it could result in the exhibitor being excused from the show. Please be conscious of anyone being brought to the show.
11. No dogs are allowed under the covered stands and arena. Failure to comply will result in a \$100 fine. If the fine is not paid within 30 days, it will result in a disqualification of the exhibitor for the respective show. If it is necessary to bring a dog to a horse show, the dog **MUST** be restrained on a leash at all times and stay at the trailers. The only exception will be Trained Service dogs; however, an owner may be asked to leave if the service dog becomes disruptive or poses a direct threat to the health and safety of others. For example, if a service dog barks repeatedly or growls at others.

12. Judges for 4-H Horse Point Shows shall be determined by the Brazoria County 4-H HAC Performance Committee. A maximum of \$400 will be allowed for judges for each show. A copy of 4-H rules will be sent to all judges by the County Extension Agent. All patterns will be sent to the Brazoria County 4-H Extension Office and the Performance Chair.

13. **Protests:** All protests must be filed in writing, accompanied by a \$200 cash fee, during or immediately upon conclusion of the event. If the protest is upheld by the Protest Committee, the deposit shall be refunded to the protester. If the protest is overruled, the deposit shall be forfeited. The Protest Committee will be composed of leaders from each 4-H Club with Horse Project participants. The “one vote per member” voting policy will be exercised by the Protest Committee in making decisions. Protests on year-end awards must be made at the conclusion of the banquet. We will NOT be posting placings.

14. Points shall be accumulated in this manner for participation in Qualifying Classes:

Contestants Per Class	1st Place	2nd Place	3rd Place	4th Place	5th Place	6th Place	7th Place	8th Place	9th Place	10th Place
1	1									
2	2	1								
3	3	2	1							
4	4	3	2	1						
5	5	4	3	2	1					
6	6	5	4	3	2	1				
7	7	6	5	4	3	2	1			
8	8	7	6	5	4	3	2	1		
9	9	8	7	6	5	4	3	2	1	
10	10	9	8	7	6	5	4	3	2	1

15. In case of death, injury, or illness of a 4-H member’s Primary Project Horse:

- a. The 4-H member may use a secondary, eligible, and validated horse providing a certified, dated letter from a veterinarian stating that the Primary Project Horse is unable to perform at the 4-H Horse Point Show in question. The letter from the veterinarian must be submitted to the HAC and County Extension Agent within 7 business days of the 4-H Horse Point Show in question. Once this is complete and approved the secondary horse may acquire points at said show.
- b. In the event that the Primary Project Horse is still unable to perform at future 4-H Horse Point Shows, a new certified, dated letter from a veterinarian will need to be provided following the same process in 15a) for the secondary horse to be used and points be acquired.
- c. In the event of the death of the Primary Project Horse, the 4-H Member may substitute the primary horse, upon validation, and veterinarian note, with a

secondary horse with approval from the voting body of the HAC as outlined in the Horse Advisory Committee of Brazoria County Bylaws.

16. At each 4-H Horse Point Show, awards will be given for class placings and overall Top 10 high point exhibitors in each division (Performance & Speed) and age group (Jr./Int. & Sr.). Special Needs and Clover Kids showing in their respective classes will also receive participation awards.
17. When an exhibitor, exhibitor's parent, or leader is guilty of poor sportsmanship, the Brazoria County 4-H Office Representative may suspend such exhibitor's rights to participate in future classes and/or shows for such a period as deemed appropriate. This includes instances of animal abuse (deemed so by the HAC).
18. When an exhibitor, exhibitor's parent or guardian, leader, or other attendee of a Horse Project activity displays poor sportsmanship, complaints must be emailed or presented in writing to the County Extension Office within five (5) days after the show. Complaints will be reviewed by the County Extension Agent and other parties as deemed appropriate. The Texas 4-H Rules of Conduct will be followed.
19. The 4-H Volunteer code of conduct must be reviewed and signed annually by all Horse Advisory Committee Members. It is available online and required from all 4-H members who sign up to volunteer.

4-H Horse Point Show Performance Rules

1. No contestant's name shall be called during the judging on performance events. Contestants shall be identified by numbers.
2. Contestants must display their numbers on their backs or saddle pads for performance events or the rider will be disqualified for the class where it is not displayed.
3. A member can enter an individual horse in only one Western Pleasure Class.
4. **Novice Western Pleasure will be held for beginning riders only. End-of-Year 1st place winners in Novice and Walk Trot must advance to a higher level pleasure class the following year.**
5. No stallions shall be allowed on show grounds on the day of the show, unless competing in the yearling halter class.
6. Invitational classes do not count in accumulating points for the Top 10 Awards. Junior/Intermediate and Senior members will both compete in the same invitational class unless age breaks are designated.
7. If a member has two or more halter horses entered in the yearling halter class, he/she may have another member of the Brazoria County 4-H Horse Project show one of his/her horses for him/her.

4-Horse Point Show Invitational Goat Tying Rules

1. Goat Tying is a timed event. Starting line will be the timer.
2. Goat shall be staked with a rope at least 10 feet in length and goat holder must hold the goat at full length of rope behind the stake, until the contestant passes the timer. A collar will be used on the goat.
3. Stake will be driven into ground so that none of it is visible.
4. Goat will be held until the contestant passes the timer.
5. The contestant must be mounted and must ride from starting line to goat, dismount, throw goat by hand (if goat is down when contestant reaches it, the goat must be cleared of the ground) and tie any 3 legs together with a string or pigging string, indicating tie is finished by a signaling of hands in air and then stand clear of goat.
6. Goat must remain tied for at least five seconds. In the event, the goat breaks the tie, and comes loose, before the 5 second time limit is up, it will result in a no time result.
7. Three (3) legs must be crossed and tied, to qualify as a legal time. Once the contestant signals his/her tie is complete, the contestant may not try to tie the goat again. If the contestant does, it will result in a no time result.
8. Time will start when the mounted contestant crosses the starting line, (timer) and will stop when the flag judge signals the completion of the tie. **The flag judge may not be a parent/guardian or family member of the contestant.**
9. Goat will be changed a minimum of every three (3) and maximum of every six (6) contestants.
10. Goats will not exceed 75 pounds.
11. Same flag man will be used for the entire event.
12. If the goat breaks loose from the stake, the contestant may receive a re-run, at the judge's discretion.

13. A Five (5) second penalty will be awarded if the contestant's horse touches the rope or goat.

4-H Horse Point Show Speed Rules

1. Contestants will be called by name for all speed events. Once the rider's name is called, they have **3 minutes** to complete their run or they will receive a "no time" for the class.
2. The back alley gate will remain closed during each run.
3. Contestants will enter and exit through the alleyway, unless advised otherwise.
4. Exhibitions will run before each speed event. Tickets for exhibitions must be pre-purchased in office prior to run.
5. Exhibitions will be run for up to **45 minutes for Cloverleaf Barrels, up to 30 minutes for Pole Bending, and 15 minutes for Straights Race**. Exhibitors should be in line waiting to run. No new tickets will be accepted and the line will be closed 10 minutes prior to the end of exhibition time.
6. During the exhibitions the alley way must remain clear.
7. Participation in exhibitions is not required, recorded, or put towards points for awards; it is strictly practice.

4-H Horse Point Show Drill/Quad

1. **Participation:** Membership in the Drill and Quad Teams is a commitment! Please see Appendix A for specific rules regarding participation in these teams. Both Drill and Quad teams will follow the rules set forth in the 2023 Texas 4-H Horse Show Rules and Regulations. Brief descriptions of Drill and Quad are below.
2. **Drill Team:** Drill team is comprised of 10-20 members who perform a routine to music that is up to 10 minutes long. Points are awarded based on horsemanship, precision of execution, difficulty of drill, and appeal to the audience.
3. **Quad Team:** A Quad team is comprised of 4 members performing between 4 and 6 minutes to music. The routine may contain any number of maneuvers; however, it must include at least three of the following six maneuvers: Pinwheel, Thread the Needle, Circle, Dizzy Serpentine, Whip, Wave.
 - **NOTE:** Each county is only allowed 3 Quad Teams to compete at the District and State 4-H Shows. In the event that we have more than 3 Quad Teams at the County level, we will have a competition to identify the teams that advance.

4-H Horse Point Show Special Needs Classes

1. **Participation:** Any 4-H member who requires assistance or accommodation to participate in the 4-H Horse Point Shows will enter the Special Needs classes. Special Needs participants may not cross entry in other classes.
2. **Accommodations:** Any accommodations required for participation need to be communicated to the 4-H Extension Office (via Cassidy Smolik) and the HAC (via bc4hhac@gmail.com) at least ten (10) days prior to the show. Please provide specific needs so that the HAC can facilitate the participation of our Special Needs members.

3. **Awards:** Classes will not be judged/timed. Awards will be based on participation in each class. Sponsorship (\$125/member) and participation (three of four point shows) are required for eligibility for end-of-year awards.

4-H Horse Point Show End-of-Year Awards Program

1. **Participation:** To be eligible for End-of-Year awards, a 4-H horse/rider team must show in **three out of four** 4-H Horse Point Shows and secure a sponsorship.
2. 4-H Horse/rider team must participate in three of the four performance shows to be eligible for End-of-Year performance awards.
3. 4-H Horse/rider team must participate in three of the four speed shows to be eligible for End-of-Year speed awards.
4. **Mandatory Sponsorship:** Each 4-H member must secure and submit sponsorships of at least \$125 to be eligible for End-of-Year awards. Sponsorship forms are available on the Brazoria County 4-H website – please use the current year’s form. **Sponsorship money will be due to the show secretary or Brazoria County 4-H Office before the exhibitor’s first competitive class at the Third Horse Point Show held.** Sponsorship money may be turned in late at the Fourth Horse Point Show but must include a \$50 late fee. You can turn any amount over the \$125 at any time but the amount turned in after June 1st will not count towards Sponsorship awards.

Sponsorship funds support our ENTIRE 4-H Horse Project! Without these funds, we would not be able to put on four horse shows, two play days, and end-of-year awards. Funds are used for ribbons and high-point trophies, insurance coverage, arena rental, tractor drivers, judges, equipment (barrels, timers, poles, trailer, etc.), and everything else that goes into a successful and vibrant 4-H Horse Project. Although the minimum requirement is \$125 at the Third Horse Point Show, we welcome any additional sponsorship funds at any time throughout the year.

5. **Work Points:** Each contestant is required to accumulate designated work points for each division (Performance and Speed) they compete in per show to be eligible for End-of-Year awards. Members must sign up the day of the show prior to book close. Work points may be satisfied by the contestant, his/her parents, associated friends, relatives, or kindly benefactors! **Don’t Forget!!** Please note, Jr./Int. 4-H members are not allowed to work within the arena due to safety concerns but can fulfill work point requirements with other responsibilities outside of the arena.
6. **Awards:**
 - A. End-of-Year Awards based on total points accumulated from four 4-H Horse Point Shows: Top 10 Awards for Jr./Int. and Sr. Speed and Jr./Int. And Sr. Performance participants. These awards may include saddles, belt buckles, or other awards if funds permit.
 - B. Invitational Event Awards: Appropriate awards will be given to participants in the invitational classes based on available funds and overall participants in those classes.
 - C. Drill/Quad Team: Appropriate awards will be given to participants in the Drill/Quad Team based on available funds and overall participation.
 - D. Special Needs Events: Appropriate awards will be given to participants based on available funds.
 - E. Sponsorship Awards: Depending on availability of funds, awards are given to 4-Hers who bring in sponsorship funds totaling \$300 or more. We encourage members to reach out to

family members, friends, local businesses, and other individuals for support of our 4-H Horse Project!

7. **Tie Breakers:** Tie breakers will be based on the number of placing's i.e. participants who have three first place wins would win over someone who only has one first place win. If the number of first place wins are the same, then the Tie Breaker will consider the number of second place wins and so on as needed. If all points and placing are even and it is in speed, add the times together and the fastest time in the Tie Breaker group will be placed higher.
8. **Perseverance Award:** This Award will be presented at the 4-H Awards Banquet if warranted. Each club may nominate up to two 4-H members by writing a small essay explaining why that 4-Her should be chosen. A final voting on Perseverance Award will be made before the Awards Program. Awards nominations must be received by the HAC before by May 31st.
9. **Sportsmanship:** To be nominated by their peers at each show. The award will be presented at the end of Brazoria County 4-H Horse Point Show.
10. **Senior Scholarships:** To recognize the achievements of our 4-H Horse Project Seniors, the HAC strives to recognize graduating seniors with scholarships with an amount depending on availability of funding. The graduating senior must be an active member of the Brazoria County 4-H Horse Project in good standing with their club for the past two years, **and be eligible for End-of-Year Awards**. Scholarship application forms can be found on the Brazoria County 4-H website and are due via e-mail to bc4hhac@gmail.com by **May 19th**.
 - a. **Scholarship recipients will be required to write a speech about their 4-H experience to be shared at the End-of-Year Awards Program.**

4-H Horse Advisory Committee (HAC)

1. All are welcome and encouraged to support the Brazoria County 4-H Horse Project! This includes 4-H Horse Project member's family, friends, and other interested individuals who support the mission and purpose of the 4-H Horse Project.
2. The HAC will meet on the 3rd Wednesday of every month at 6:30 pm; other meetings are scheduled on an as-needed basis. Please check the Brazoria County 4-H and Brazoria County 4-H Horse Project Facebook pages to verify dates of meetings. Individuals do not need to be an HAC member to attend the HAC meetings. ALL 4-H Horse Project member parents are encouraged to attend these meetings.
3. **Hardship Clause:** The HAC has the authority to rule if a hardship exists or to clarify any situation that may arise that is not specifically covered by these rules. If such an event occurs, the 4-H member must notify the 4-H County Extension Office in writing providing information on the hardship/situation and the resolution being requested. The HAC will review the provided information, requesting additional information, if needed, and make a decision. Special situations may be considered under the hardship clause. Exhibitors must contact the county agent regarding hardship situations before the show deadline.
4. Financial year for Brazoria County 4-H Horse Project will be from September 1st through August 31st. HAC leaders will also serve September 1st through August 31st.

2024 – 2025 Brazoria County 4-H Horse Advisory Committee (HAC) Leaders

Chair Person: Nancy Hughes	Co-Chair Person: Suzanne Schaffer	Social Media: Haley Biggers
Show Secretary: Natalie Hoelscher	Performance / Invitational Judged Committee: Taren Harris	Speed / Invitational Speed Committee: Debra Land and Haley Biggers
Quad/Drill Committee:	Fundraiser Chair: Grant Coffman	Awards Chair:
Banquet Committee: Tonya Young	Treasurer: Grant Coffman	County Extension Agent: Cassidy Smolik



Appendix A
Quad/Drill/Precision
Rules
(2023 Texas State 4-H Rules)

Quad Drill General Rules

1. Each Drill Team member is required to comply with the Texas 4-H membership requirements.
2. Teams may contain 4 riders with 1 alternate per "Quad".
3. Each county will be allowed only 3 teams per county for the state 4-H Horse Show, with no re-occurring riders on Quad teams.
4. A horse will be allowed for competition in Drill and Quad. A hardship substitution will be allowed with a vet notice.
5. Commands executed during the drill must be made by a drill team member performing in the drill.
6. Commands may be executed using the following methods: voice, hand gestures, or whistle. Use of whistles is encouraged. Excessive use of whistles will be scored lower. Teams without whistles will be judged as a higher level difficulty.
6. All drills can begin and end on an open gate arena.
7. Costumes and Music should reflect theme and be 4-H appropriate. Costumes will not be judged as strongly as Horsemanship.
8. Quad Drills may contain the following gaits: walk, trot, lope, or canter.
9. Teams are responsible for their own music, music will NOT be provided.
10. Use of any markers or props set either in or around the arena is prohibited.
11. A mandatory coaches/team adult representative meeting will be scheduled prior to the class at the State 4-H Horse Show.
12. A time-out may be allowed by judges in case of an accident or fall.
13. The guidelines for western style follow the standards described under 4-H Speed event rules listed in the Texas 4-H Horse Program Rule Book, with the following exception: Snaffle bits, bosals and hackamores can be used on a horse of any age. Tie downs are allowed in western style riding.
14. The guidelines for English style follow the standards described under English Division in the Texas 4-H Horse Program Rule Book.
15. Use of bats, whips, crops in western are not allowed.

Class Routine

1. Riders may ride Western or English style. However, all four riders must ride the same style.
2. Drill can begin with riders entering the arena and lining up where their drill will begin or they can begin with an open gate.
3. The music begins when the drill lead acknowledges the judge by a loud whistle.
4. Drill length should be a minimum of 4 minutes and a maximum of 6 minutes.
5. Drills may contain any number of maneuvers; however, a quad drill must include at least three of the following six maneuvers: - Pinwheel - Thread the Needle - Circle - Dizzy Serpentine - Whip - Wave All maneuvers listed can be found in "101 Drill Team Exercises for Horse and Rider" by Debbie Sams Equipment

Definitions

Drill Team - A group of horse and riders performing a specific class. Such as Freestyle, Freestyle 5 riders and under, Quad or Compulsory.

Drill Master - The leader responsible for the team. The drill master does not ride with the team.

Drill leader/leads - Youth performing in the drill who execute commands during the drill to other team members.

Alignment - Vertical and horizontal alignment for both maneuvers and transitions. Transitions - The action taken between maneuvers.

Spacing - Uniform distance which may be varied in different maneuvers or transitions. Spacing at any given time should be consistent.

Variety - Drill variety includes movements; i.e., single file, pairs, fours etc. variety of speed, and variety of ways the drill is performed.

Coordination and timing - The manner in which the members work as a team to perform their drill. Includes music coordination with drill movement.

Legal Flag Holder - A flag holder that attaches to the stirrup or saddle (not the rider) and does not impede the rider. It shall allow the flag to stay firmly in place and be safe for the rider.

Horsemanship/Equitation - Horsemanship/Equitation will be stressed as adapted for drill purposes.

Faults listed under rules for Western Horsemanship and English Equitation in the Minnesota 4-H Horse Program Rule Book are considered during a drill performance but considerations are in place for it is recognized that this is a drill and therefore leniency is given accordingly.

Performance of horses - Manners, way of going and suitability of the horse for the drill performed.

Briskness - Precision, alignment, spacing and coordination of horses and riders executing maneuvers with excitement and energy. A clean performance with a positive attitude from both horse and rider.

Degree of Difficulty - This defines how spectacular a maneuver is performed. Speed is noted because a faster tempo; gait raises the difficulty of performing a given maneuver. Precision should not be sacrificed for speed.

Drill and Precision Divisions

This division contains two separate classes: drill and precision riding teams. Teams (in total or in part) may participate in either the drill class or the precision riding class or both.

Objectives:

- 1) To teach boys and girls teamwork.
- 2) To provide opportunities to demonstrate democratic procedure and group action.
- 3) To teach horsemanship and horse safety to 4-H members.
- 4) To provide an organized and supervised activity for 4-H members with horses.

Requirements

- 1) Youth must be enrolled in 4-H with a horse project and meet all 4-H membership requirements.
- 2) Horse ownership by the 4-H member is mandatory. See ownership rules.
- 3) Mounted teams must establish membership requirements with a specific program of teaching and practice. Youth must meet all requirements of the mounted team of which they are members.
- 4) All riders on a team must be from the same or adjacent county.

Organization

- 1) Mounted teams may be formed from existing project groups, horse clubs, and/or other 4-H members with horse projects.
- 2) More than one team may come from a single county.
- 3) One adult leader will be selected as the team master. Assistants to the team master may be appointed.
- 4) The 4-H members may elect a team captain and other officers as needed.

Drill Class

- 1) The use of props by drill teams is prohibited at the District and State Shows. There will be no pyrotechnics or smoke of any kind.
- 2) No pre-recorded introductory commentary will be allowed prior to or during the drill competition. Each team will be introduced by the announcer prior to the performance.
- 3) Each drill routine should be no longer than 10 minutes. Two points will be deducted from each judge's score card for each minute the drill routine exceeds the 10 minutes. At least 3 seconds of each minute over 10 minutes must be consumed before the penalty is assessed. The 10- minute allowance begins when the first horse enters the arena and ends when the last horse leaves the arena. Time consumed as a result of an accident or other unforeseen circumstances that require stopping the drill is NOT counted as part of the 10-minute time allowance.
- 4) Teams shall be composed of no fewer than 10 members and no more than 20 members. (Teams may have larger membership, but routines will be developed for these minimum and maximum numbers of members.)
- 5) Drills will be judged as a group, with credit given for horsemanship, precision of execution, difficulty of drill, and appeal to the audience.
- 6) A fall of the horse and/or rider (each occurrence) will result in a Five-point penalty, to be subtracted from the total score.
- 7) A collision – Five-point penalty. A collision is defined when two horses actually collide with each other causing a change in speed and/or direction or stopping the maneuver. Drill Team Score Sheet Drill teams will be scored on the following 40 point system. 111 Precision of Execution (alignment of files and ranks, maintenance of distances, intervals and gaits) – 14 points Horsemanship (position in saddle and control of mount) – 12 points Difficulty of Drill (intricacy and variety of maneuvers, speed/gait variation, spacing) – 8 points Appeal to Audience (entry/exit, theme, uniformity, uniform/equipment, originality, music, showmanship, choreography) – 6 points

Precision Riding Teams

- 1) All precision riding teams will ride the same standard routine found in the State 4-H Horse Show Rules. See figure below. No time limits will be placed on this routine; however, the standard routine will be designed to be completed in less than 15 minutes. Standard background music WILL NOT be provided for all teams. Music MUST BE an instrumental piece.
- 2) No pre-recorded introductory commentary will be allowed prior to the precision competition. Each team will be introduced by the announcer prior to the performance.
- 3) The standard Western dress will be casual pants (blue jeans, denim, cotton, etc.; no dress pants are allowed) and a plain white shirt or blouse. The standard hunter dress will be breeches or jodhpurs, a hunter-type blouse or shirt, a hunter-type hat, and boots. Coats should not be worn.
- 4) No matching coats, vests, sweaters, etc., are allowed.
- 5) The following items may match, but matching items are not required. a. Hats, ties, or neck scarves for riders. b. Leg wraps, saddle blankets, bridles, and breast collars for horses.
- 6) The precision riding team shall be made up of an even number of riders, with a minimum of 8 riders and a maximum of 20 riders. Precision Riding Score Sheet The whole group will be judged based on horsemanship ability (45), precision of execution of standardized routine (45), and team appearance (10).
- 7) If you are interested in Precision Riding the Pattern will be available upon request.



Appendix B

Stock Horse Pleasure

(Texas State 4-H 2023 Rules and Regulations)

Stock Horse Pleasure

This class serves to measure the ability of the horse to be functional and a pleasure to ride while being used as a means of conveyance from one task to another. This horse should be well-broke, relaxed, quiet, soft, and cadenced at all gaits. The horse should be ridden on a relatively loose rein with light contact and without requiring undue restraint. Excessively long, floppy reins will not be given extra credit. The horse should be responsive to the rider and make all required transitions smoothly, timely, and correctly. The horse should be soft in the bridle and yield to contact. Horses shall be shown individually at the walk, trot, and lope in both directions. The walk, trot, and lope will be extended in one direction only. Markers set up in the arena will designate gait changes. The pleasure course shall be set to make approximately one pass of the arena in each direction. The pattern may be started either in the left or right direction.

The order of gaits shall be:

- 1) extended walk
- 2) trot
- 3) extended trot
- 4) lope
- 5) stop and reverse
- 6) walk
- 7) lope
- 8) extended lope
- 9) trot
- 10) stop and back

Description of Ideal Pleasure Gaits

The ideal pleasure horse will have a level head carriage at each gait – neither too high nor too low.

Walk – The walk should be straight, square, flat footed, relaxed, and should move out freely with horse looking ahead.

Extended Walk – The extended walk should be straight, square, flat footed, relaxed, and should move out freely with horse looking ahead, It should show more length of stride than the ordinary walk.

Trot – This gait should be a square two-beat diagonal trot. The trot should be steady, soft, and slow enough for riding long distances. Trots which are too fast, rough and hard to sit should be penalized. Excessively slow and uncadenced trots should also be penalized.

Extended Trot – The extended trot should show a definite lengthening of stride from the regular trot with the same cadence, which will cause an increase in speed. This trot should be level, flat, and steady with the appearance that the horse could hold this gait for an extended distance. The method riders chose to ride the extended trot is optional. It is acceptable to either post at the trot, sit, or stand in the stirrups, while holding the saddle horn, at the extended trot only.

Lope – This gait should be a three-beat gait that is collected, cadenced, straight and steady and is comfortable to ride.

Stop (from both lope and trot) – The horse should be in the correct stopping position – both hocks engaged and stopping on the hindquarters.

Reverse – A horse should turn briskly and flat with front feet on the ground and holding an inside rear pivot foot.

Extended Lope – This gait should be an obvious lengthening of stride from the previous lope, be at the same cadence and cause an increase in speed. The gait needs to be steady, quiet, and holding the increased speed while being under complete control.



Appendix C
Patterns

Reining Patterns #1-10

Cloverleaf Pattern

Pole Bending

Stakes Race

(These patterns are set by
Texas State 4-H 2023 Rules and Regulations)

Reining Pattern #1

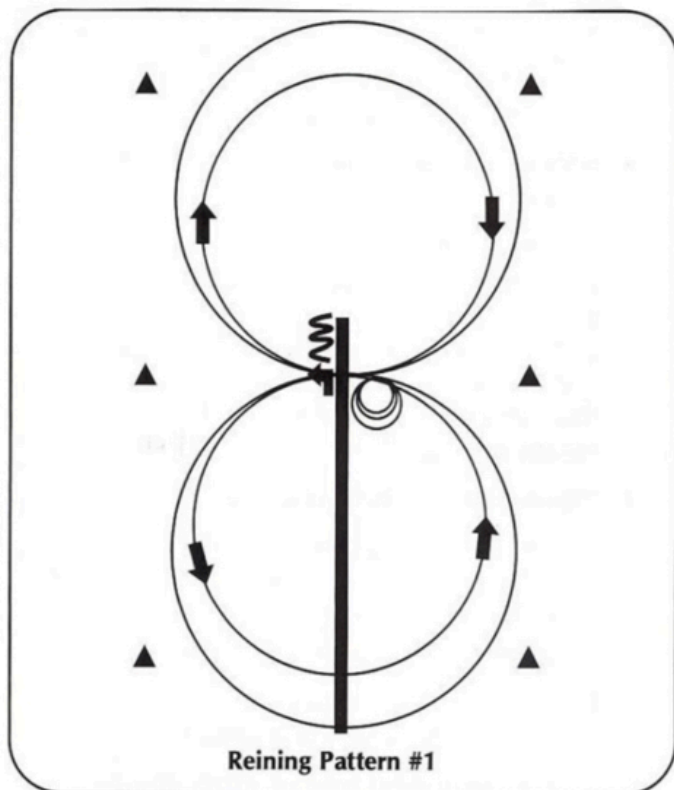

1. Run down center of arena past center marker, stop and back up. Hesitate.
2. Make a quarter turn to the left.
3. Lope a large, fast circle to the right, followed by a small, slow circle to the right. Change leads.
4. Lope a large, fast circle to the left, followed by a small, slow circle to the left.
5. Stop.
6. Complete four spins one direction. (Choose to spin four times to either the left or the right, your choice.)
7. Pattern complete. Exit the arena.

Reining Pattern #2

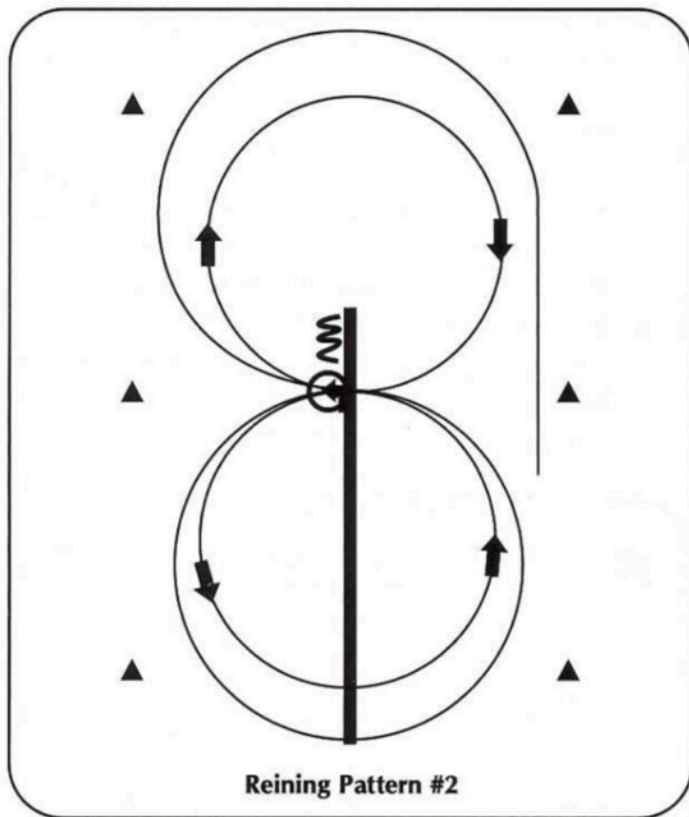

1. Run down center of arena past center marker, stop and back up. Hesitate.
2. Do four and one-quarter spins to the left.
3. Lope a small, slow circle to the left, followed by a large, fast circle to the left. Change leads.
4. Lope a small, slow circle to the right.
5. Begin a large, fast circle to the right, but do not close circle.
6. Run straight down the right side of the arena past center marker and stop.
7. Pattern complete. Exit the arena.

Reining Pattern #3

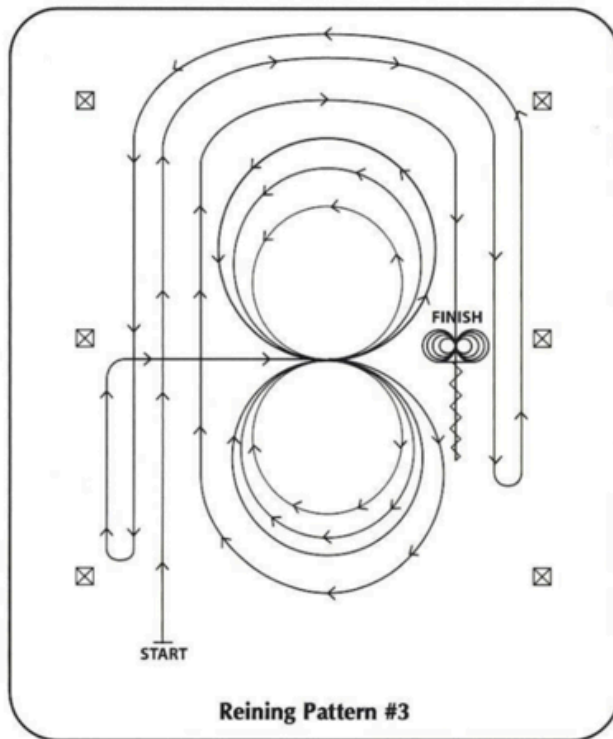

1. Beginning and staying at least 20 feet from the walls or fence, lope straight up the left side of the arena, circle the top end of the arena, run straight down the opposite or right side of the arena past the center marker, and do a left rollback – no hesitation.
2. Continue straight up the right side of the arena staying at least 20 feet from the walls or fence, circle back around the top of the arena, run straight down the left side of the arena past the center marker, and do a right rollback – no hesitation.
3. Continue up the left side of the arena to the center marker. At the center marker, the horse should be on the right lead. Guide the horse to the center of the arena on the right lead, and complete three circles to the right: the first two circles large and fast; the third circle small and slow. Change leads at the center of the arena.
4. Complete three circles to the left: the first two circles large and fast; the third circle small and slow. Change leads in the center of the arena.
5. Begin a large, fast circle to the right but do not close this circle. Continue up the left side of the arena staying at least 20 feet from the walls or fence, circle the top of the arena, run straight down the opposite or right side of the arena past the center marker, and do a sliding stop. Back up at least 10 feet. Hesitate.
6. Complete four spins to the right.
7. Complete four spins to the left. Hesitate to demonstrate completion of the pattern.

Begin at the center of the arena facing the left wall or fence.

Reining Pattern #4

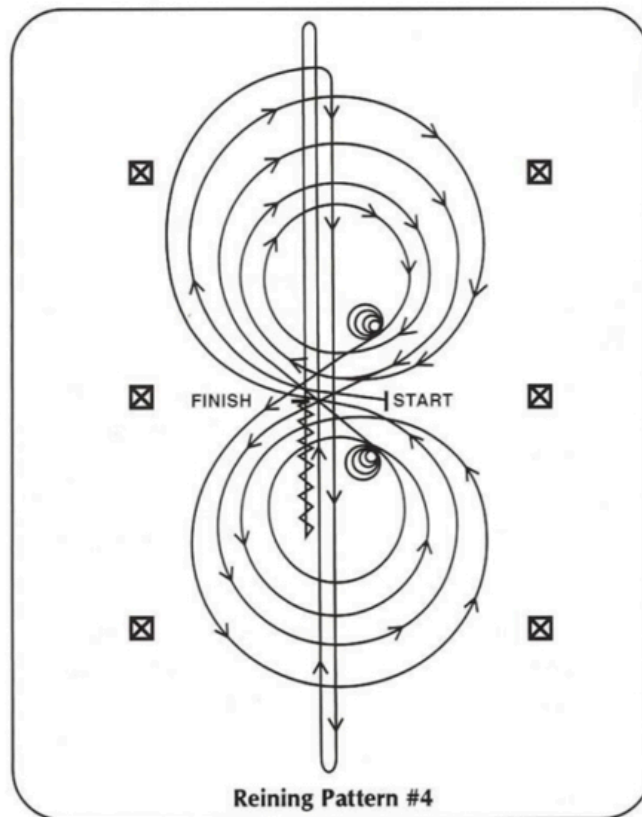

1. Beginning on the right lead, complete three circles to the right: the first two circles large and fast; the third circle small and slow. Stop at the center of the arena.
2. Complete four spins to the right. Hesitate.
3. Beginning on the left lead, complete three circles to the left: the first two circles large and fast; the third circle small and slow. Stop at the center of the arena.
4. Complete four spins to the left. Hesitate.
5. Beginning on the right lead, run a large fast circle to the right, change leads at the center of the arena, run a large fast circle to the left, and change leads at the center of the arena.
6. Continue around previous circle to the right. At the top of the circle, run down the middle to the far end of the arena past the end marker, and do a right rollback – no hesitation.
7. Run up the middle to the opposite end of the arena past the end marker, and do a left rollback – no hesitation.
8. Run past the center marker, and do a sliding stop. Back up to the center of the arena or at least 10 feet. Hesitate to demonstrate completion of the pattern.

Reining Pattern #5

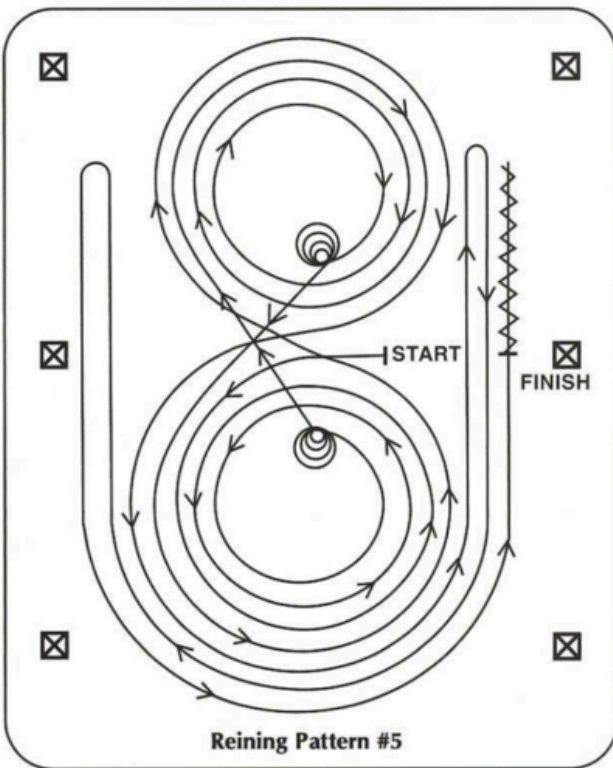

Begin at the center of the arena facing the left wall or fence.

1. Beginning on the left lead, complete three circles to the left: the first two circles large and fast; the third circle small and slow. Stop at the center of the arena.
2. Complete four spins to the left. Hesitate.
3. Beginning on the right lead, complete three circles to the right: the first two circles large and fast; the third circle small and slow. Stop at the center of the arena.
4. Complete four spins to the right. Hesitate.
5. Beginning on the left lead, run a large fast circle to the left, change leads at the center of the arena, run a large fast circle to the right, and change leads at the center of the arena.
6. Continue around previous circle to the left but do not close this circle. Run up the right side of the arena past the center marker, and do a right rollback at least 20 feet from the wall or fence – no hesitation.
7. Continue around previous circle to the right, but do not close this circle. Run up the left side of the arena past the center marker, and do a left rollback at least 20 feet from the wall or fence.
8. Continue back around previous circle to the left, but do not close this circle. Run up the right side of the arena past the center marker, and do a sliding stop at least 20 feet from the wall or fence. Back up at least ten feet. Hesitate to demonstrate completion of the pattern.

Reining Pattern #6

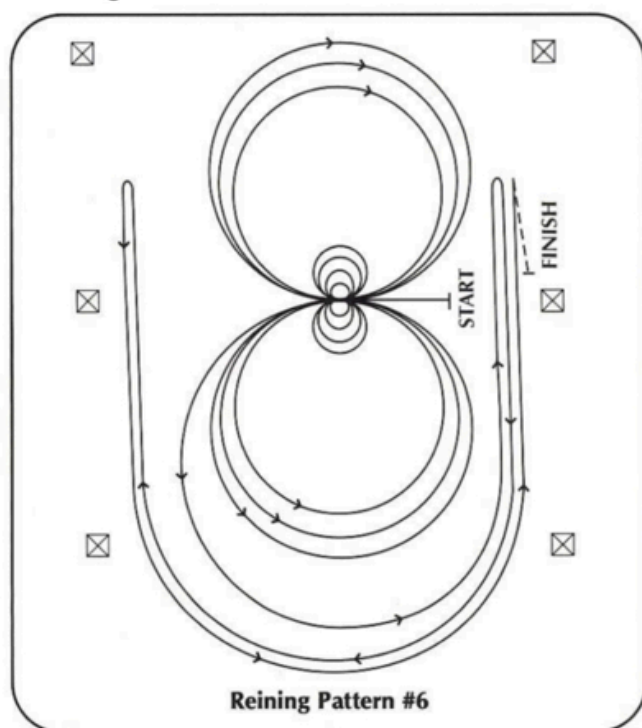

1. Walk to the center of the arena; the horse should be facing the left wall or fence.
2. Complete four spins to the right.
3. Complete four spins to the left.
4. Beginning on the left lead, complete three circles to the left: the first two circles large and fast; the third circle small and slow. Change leads at the center of the arena.
5. Complete three circles to the right: the first two circles large and fast; the third circle small and slow. Change leads at the center of the arena.
6. Begin a large fast circle to the left, but do not close this circle. Run up the right side of the arena past the center marker, and do a right rollback at least 20 feet from the wall or fence – no hesitation.
7. Continue back around the previous circle to the right, but do not close this circle. Run up the left side of the arena past the center marker and do a left rollback at least 20 feet from the wall or fence – no hesitation.
8. Continue back around the previous circle to the left, but do not close this circle. Run up the right side of the arena past the center marker, and do a sliding stop at least 20 feet from the wall or fence. Back up at least 10 feet. Hesitate, to demonstrate a completion of the pattern.
9. The bridle may be dropped at the judge's discretion.

Reining Pattern #7

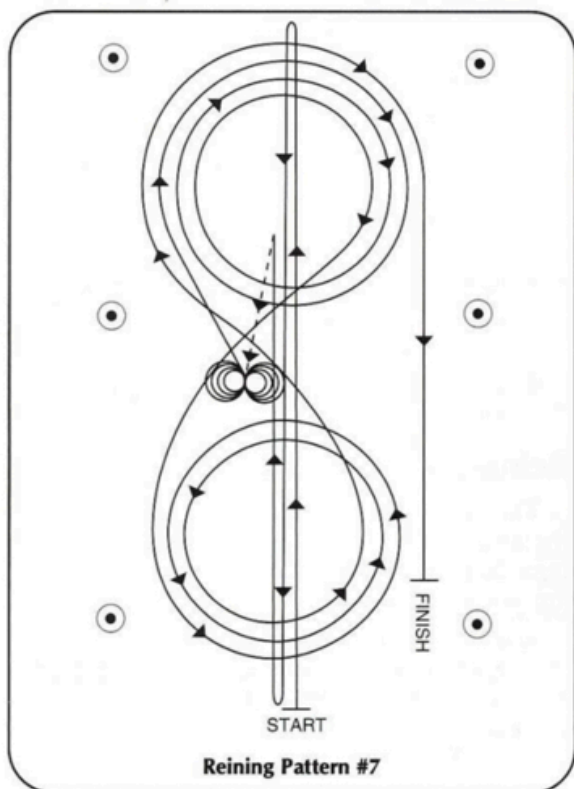

The judge shall indicate with markers on the arena fence or wall the length of the pattern. Markers within the area of the pattern are not permitted.

1. Run with speed to the far end of the arena past the end marker, and do a left rollback. Do not hesitate.
2. Run to the opposite end of the arena past the end marker, and do a right rollback. Do not hesitate.
3. Run past the center marker of the arena, do a sliding stop, and back straight to the center of the arena. Hesitate.
4. Complete four spins to the right.
5. Complete four and one-quarter spins to the left. Hesitate.
6. Beginning on the right lead, complete three circles to the right, the first two circles large and fast, the third circle small and slow. At the center of the arena, change leads.
7. Complete three circles to the left, the first two circles large and fast, the third circle small and slow. At the center of the arena, change leads.
8. Begin a large fast circle to the right. Do not close this circle, but run straight down the side of the arena past the center marker, and do a sliding stop approximately 20 feet from the wall or fence. Hesitate, to demonstrate the completion of the pattern.
9. The bridle may be dropped at the judge's discretion.

Reining Pattern #8

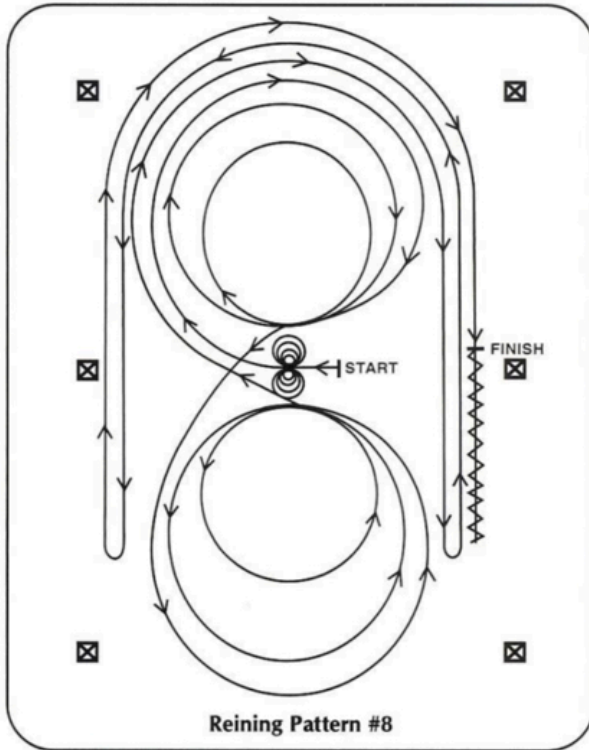

Begin at the center of the arena facing the left wall or fence.

1. Complete four spins to the left.
2. Complete four spins to the right. Hesitate.
3. Beginning on the right lead, complete three circles to the right: the first circle large and fast; the second circle small and slow; the third circle large and fast. Change leads at the center of the arena.
4. Complete three circles to the left: the first circle large and fast; the second circle small and slow; the third circle large and fast. Change leads at the center of the arena.
5. Begin a large fast circle to the right, but do not close this circle. Run straight down the right side of the arena past the center marker, and do a left rollback at least 20 feet from the wall or fence – no hesitation.
6. Continue back around the previous circle to the left, but do not close this circle. Run down the left side of the arena past the center marker, and do a right rollback at least 20 feet from the wall or fence – no hesitation.
7. Continue back around the previous circle to the right, but do not close this circle. Run down the right side of the arena past the center marker, and do a sliding stop at least 20 feet from the wall or fence. Back up at least 10 feet. Hesitate to demonstrate completion of the pattern.

Reining Pattern #9

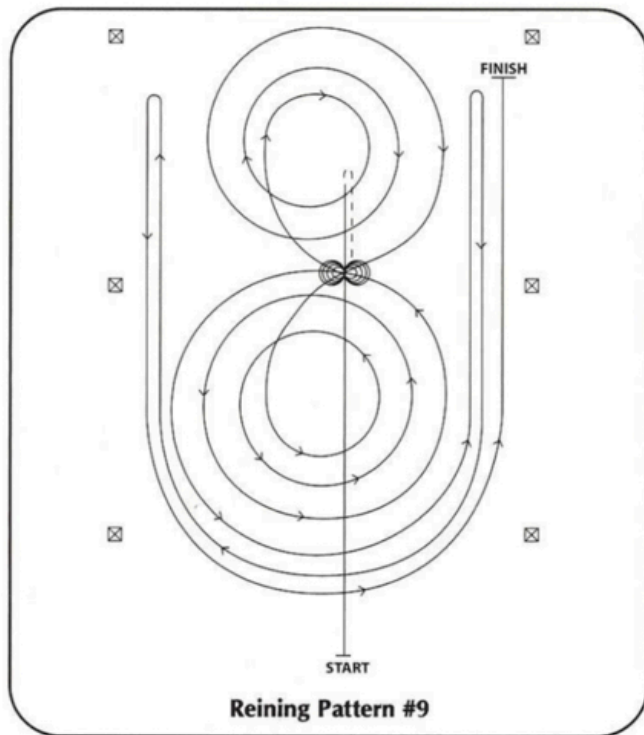

1. Run past the center marker, and do a sliding stop. Back up to the center of the arena or at least 10 feet. Hesitate.
2. Complete four spins to the right.
3. Complete four and one-quarter spins to the left, so that the horse is facing the left wall or fence. Hesitate.
4. Beginning on the left lead, complete three circles to the left: the first circle small and slow; the next two circles large and fast. Change leads at the center of the arena.
5. Complete three circles to the right: the first circle small and slow; the next two circles large and fast. Change leads at the center of the arena.
6. Begin a large, fast circle to the left, but do not close this circle. Run up the right side of the arena past the center marker, and do a right rollback at least 20 feet from the wall or fence – no hesitation.
7. Continue back around the previous circle to the right, but do not close this circle. Run up the left side of the arena past the center marker, and do a left rollback at least 20 feet from the wall or fence – no hesitation.
8. Continue back around previous circle to the left, but do not close this circle. Run up right side of the arena past the center marker, and do a sliding stop at least 20 feet from the wall or fence. Hesitate to demonstrate completion of the pattern.

Reining Pattern #10

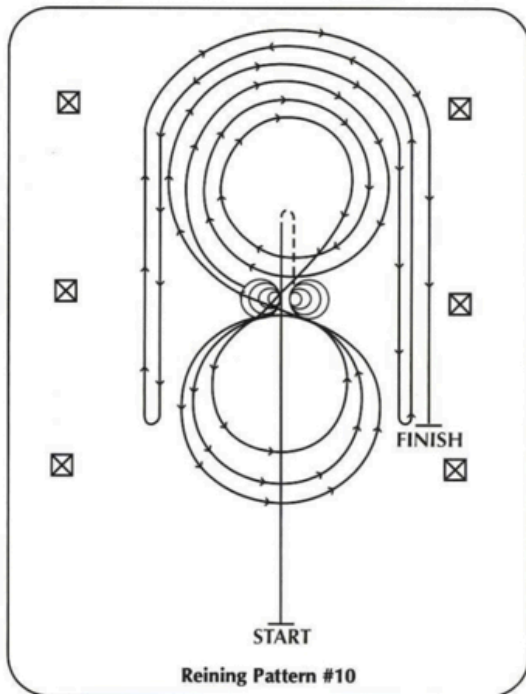

1. Run past the center marker, and do a sliding stop. Back up to the center of the arena or at least 10 feet.
2. Complete four spins to the right.
3. Complete four and one-quarter spins to the left, so that the horse is facing the left wall or fence. Hesitate.
4. Beginning on the right lead, complete three circles to the right: the first two circles large and fast, the third circle small and slow. Change leads at the center of the arena.
5. Complete three circles to the left: the first circle small and slow, and the next two circles large and fast. Change leads at the center of the arena.
6. Begin a large fast circle to the right, but do not close this circle. Run down the right side of the arena past the center marker, and do a left rollback at least 20 feet from the wall or fence – no hesitation.
7. Continue back around the previous circle to the left, but do not close this circle. Run down the left side of the arena past the center marker, and do a right rollback at least 20 feet from the wall or fence – no hesitation.
8. Continue back around the previous circle to the right, but do not close this circle. Run down the right side of the arena past the center marker, and do a sliding stop at least 20 feet from the wall or fence. Hesitate, to demonstrate a completion of pattern.
9. The bridle may be dropped at the judge's discretion.

Barrel Racing

1. Failure to follow the pattern is a **Disqualification**, backing is considered a broken pattern
2. Knocking over a barrel shall carry a 5 second penalty.
3. The course must be measured exactly. If the pattern is too large for the available space, the pattern should be adjusted by the show officials to fit the arena. Remember to leave adequate space between the barrels and the arena fence (approximately 20 feet), and set the course to allow ample room for stopping.
4. The barrel racing contest is strictly a timed event. An electric timer should be used for official time. If one is not available, the average time of at least two watches will be the official time.
5. In the event of a tie, the horse declared the winner in the runoff must run the pattern in not more than two seconds more than its original time, or the runoff must be held again.
6. The exhibitor is allowed a running start. Timing shall begin as soon as the horse's nose reaches the starting line and will be stopped when the horse's nose passes over the finish line.
7. At a signal from the starter or timer, the exhibitor will go to barrel number 1, turning to the right around this barrel, then on to barrel number 2, this time turning to the left. At barrel number 3, the exhibitor makes the same left turn around this barrel.
8. As soon as the turn is completed around the third barrel, the exhibitor sprints the horse to the finish line.
9. This barrel course may also be run to the left. For example, the exhibitor will start to barrel number 2, turning to the left around this barrel, then to barrel number 1, turning to the right, then to barrel number 3, turning to the right, followed by the final sprint to the finish line. (See barrel racing pattern.)
10. An exhibitor touching a barrel with hand or body is NOT a disqualification.

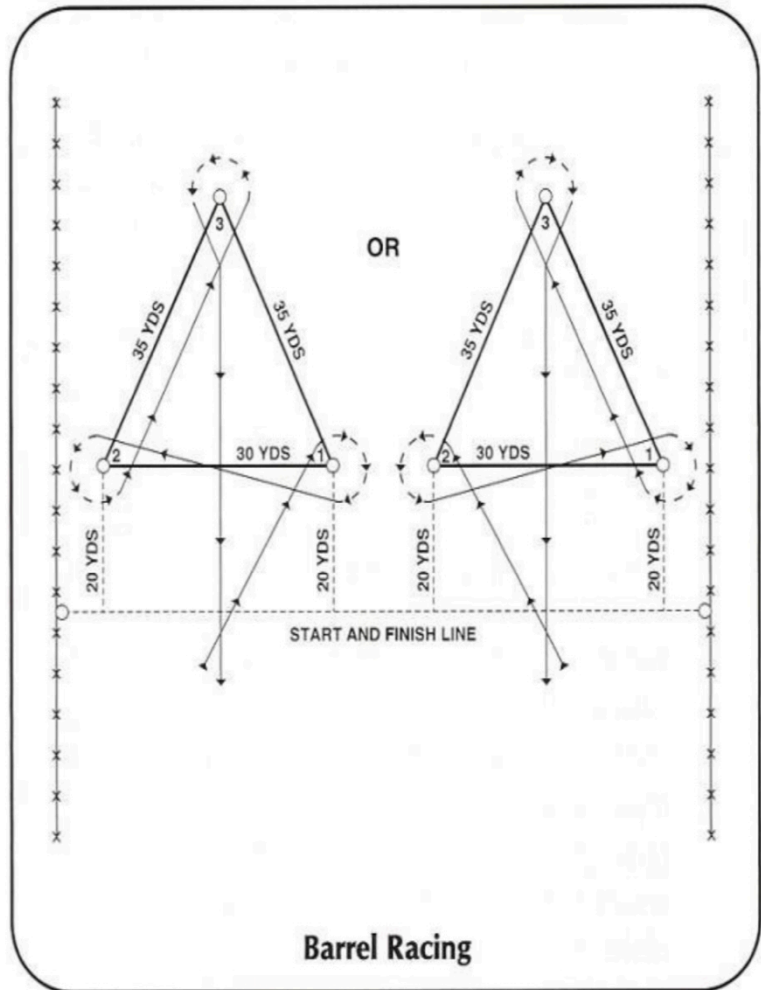

Pole Bending

1. The pole bending pattern is to be run around six poles. The poles are to be 21 feet apart, with the first pole 21 feet from the starting line.
2. A horse may start either to the right or to the left of the first pole and then run the remainder of the pattern accordingly (see the Pole Bending diagram).
3. Failure to follow the pattern shall cause **Disqualification**, Backing is considered a broken pattern
4. Knocking over a pole shall carry a 5 second penalty.
5. Pole bending is a timed event. Each contestant will begin from a running start. A clearly visible starting line should be provided. An electric timer should be used when possible. Otherwise, at least two watches should be used with the average time of the watches to be the official time.
6. In the event of a tie, the horse declared the winner in the runoff must run the pattern in no more than 2 seconds more than its original time, or the runoff must be held again.
7. It is recommended that all poles have at least a 14-inch base.
8. Touching a pole with hand or body is NOT a disqualification.

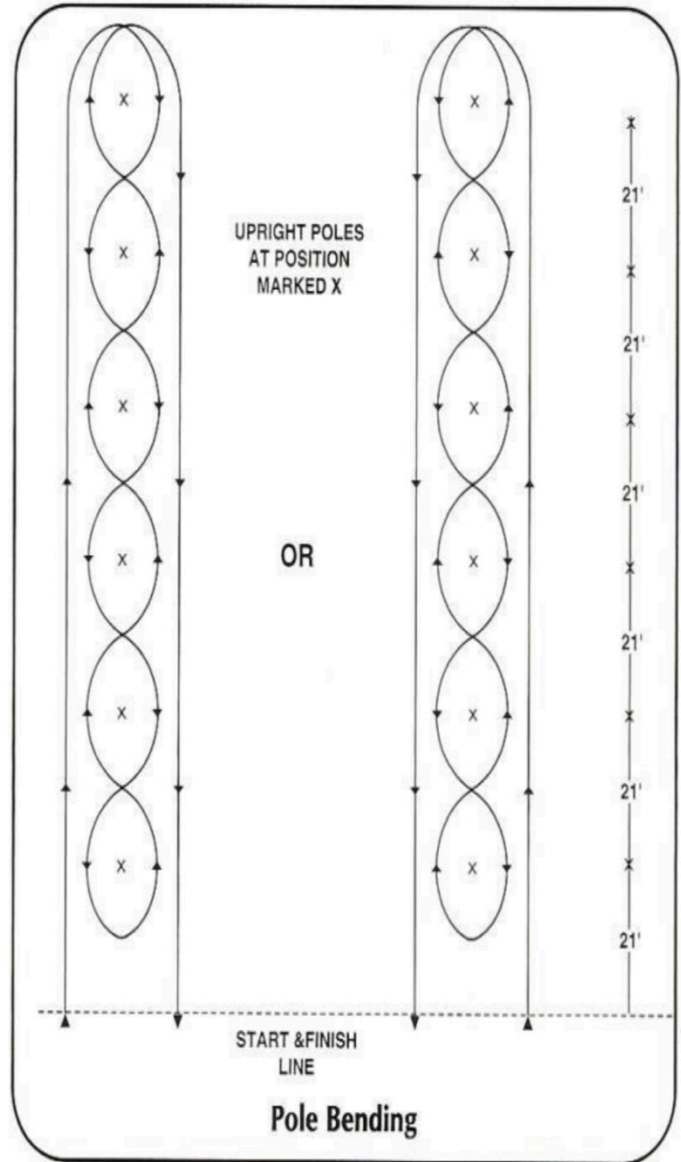

Stake Race

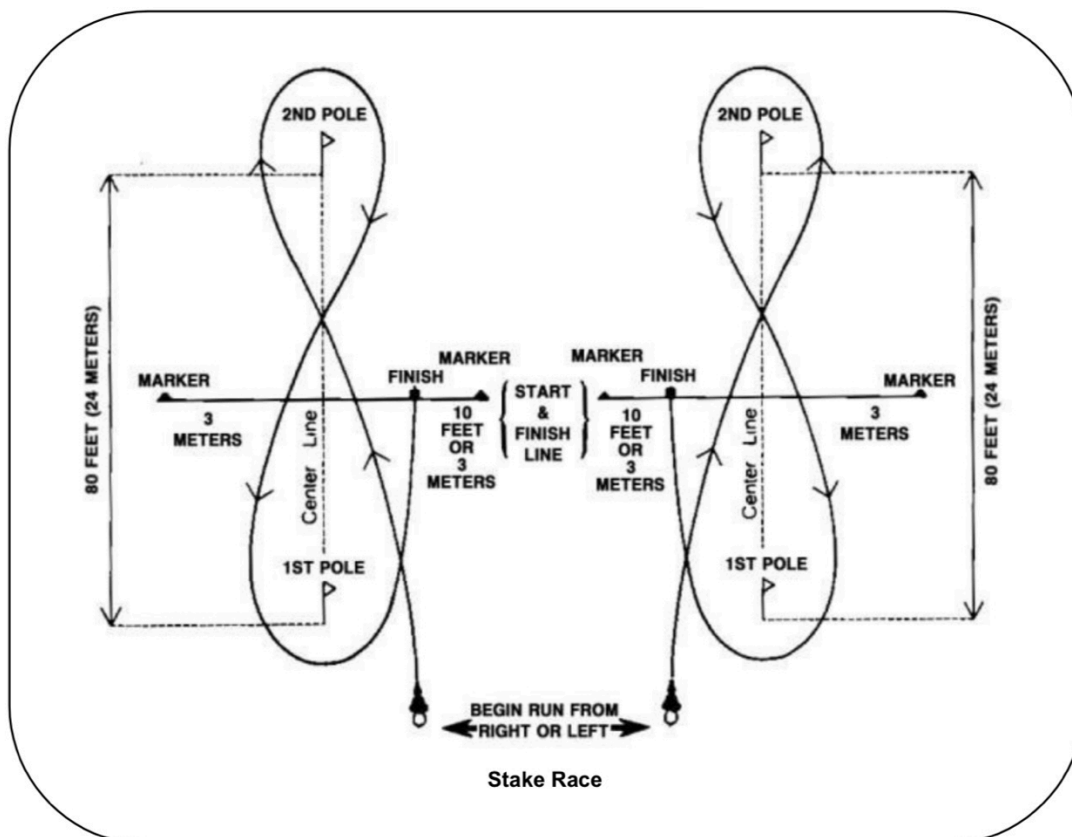

1. This is a timed event, run with the gate closed.
2. Two poles are set 80 feet apart at opposite ends of the course. Two markers designate the start-finish line 20 feet apart mid-way between the two end poles.
3. Timing shall begin as soon as the horse's nose reaches the starting line and will be stopped when the horse's nose passes over the finish line.
4. The exhibitor is allowed a running start and may begin the run from either the left or right side of the first pole. **Horses MUST start by crossing the center line between the upright markers, turn around the second pole, cross over the center line again between the markers, then around the first pole and run back across the finish line.**
5. Failure of an exhibitor to cross the start and finish line between the markers shall result in **NO TIME**.
6. Failure of an exhibitor to cross over the center line between the markers before turning the second pole shall result in **NO TIME**.
7. Backing is considered a broken pattern and will result in a **NO TIME**.
8. An exhibitor may touch the end pole(s) with his or her hand in the stakes race. Knocking over any of the poles or markers is a **NO TIME**. **At the State Show, exhibitors will ride to a closed gate.**



Appendix D
Bits & Equipment

Bits and Equipment

Texas State 4-H Horse Show Rules and Regulations

NOTE: Rules and regulations regarding 2-year old and 3-year old futurity classes offered at District and State have been removed from these slides, please see full information on the State 4-H Horse Show website.

Snaffle Bit

A bit where the headstall, keeper and reins all attach to one ring and are free-moving



Uses direct pressure, not leverage

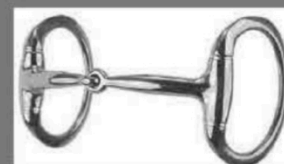
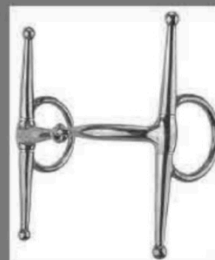

Curb Bit

A bit where the headstall, curb chain and reins attach at different locations



Uses leverage

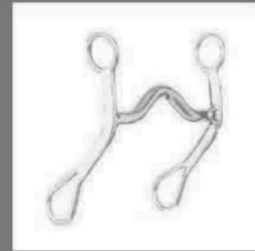
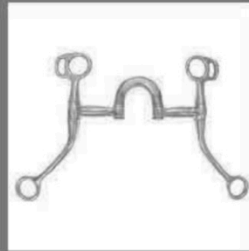

Western Performance Classes

Legal Bits

Curb



Spade



Half-breed



Western Performance Classes

Legal Bit Examples

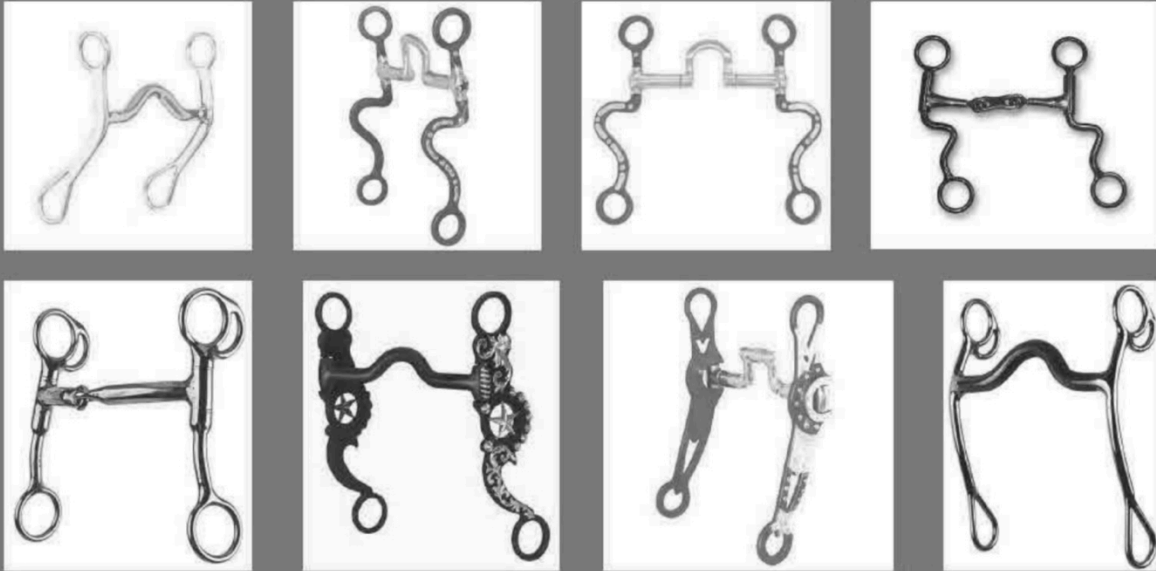

Western Performance Classes

Curb bits

Shanks no longer than 8½" (total of upper and lower shank)

Port no higher than 3"

Curb chains and straps at least ½" wide and lie flat

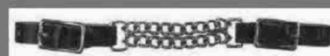
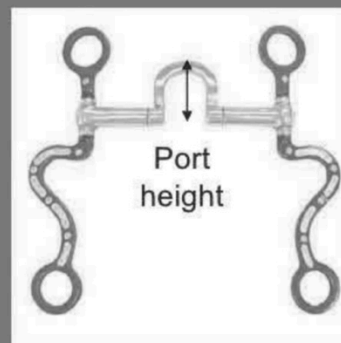

Western Performance Classes

Curb bits

Mouthpieces

Round, oval or egg shaped

Smooth and unwrapped metal of $\frac{5}{16}$ " to $\frac{3}{4}$ " in diameter measured 1" from the cheek

Nothing may protrude below mouthpiece

(ex: extensions or prongs)

May be 2 or 3 pieces

3 piece connecting ring of $1\frac{1}{4}$ " or less in diameter, or a connecting flat bar of $\frac{3}{8}$ " or $\frac{3}{4}$ " (top to bottom) with a maximum length of 2" which lies flat in mouth is acceptable

Western Performance Classes

Illegal Equipment Snaffles

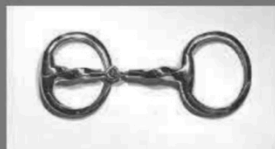

Western Performance Classes

Illegal Equipment
Bosal



Western Performance Classes

Illegal Equipment
Mechanical hackamore



Western Performance Classes

Illegal Equipment Gag bits

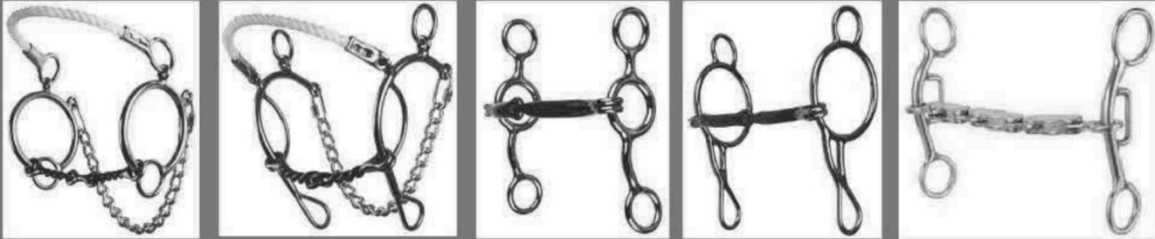

Western Performance Classes

Illegal Equipment Prong Bits



Western Performance Classes

Illegal Equipment
Excessive Port



Western Performance Classes

Illegal Equipment
Twisted mouthpieces

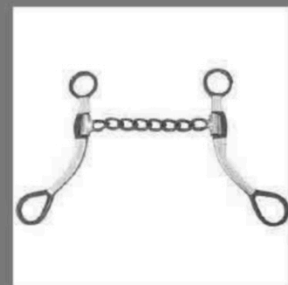

Western Performance Classes

Illegal Equipment

Martingale



Tie down



Noseband



Western Performance Classes

Illegal Equipment

Draw reins



Western Performance Classes

Illegal Equipment Protective boots and leg wraps



Not allowed in halter, showmanship, western pleasure, western riding or trail

Timed Event Classes

Western-type equipment
must be used
Mechanical hackamore,
gag bit or other bridle is
contestant's choice
Tie downs are legal



Hunter Performance Classes

Legal Equipment

Snaffle

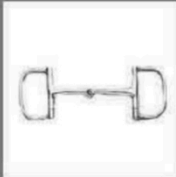

Kimberwick



Pelham

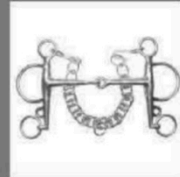

Full bridle

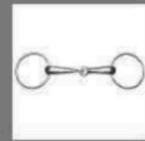

Note: Pelham bits and Full bridles must be used with two sets of reins.

Hunter Performance Classes

Legal Equipment

Cavesson noseband
(mandatory)



Breastplate
(optional)



Hunter Performance Classes

Mouthpieces

Nothing may protrude below mouthpiece

Solid and broken mouthpieces must be between 5/16" to 3/4" diameter

May be inlaid, synthetic wrapped, including rubber or plastic or incased, but must be smooth

On broken mouthpieces only, connecting rings of 1 1/4" or less in diameter or connecting flat bar of 3/8" to 3/4" (top to bottom) with max length of 2" which lie flat in mouth are acceptable

Snaffle bit rings no larger than 4"

Any bit with fixed rein requires curb chain

Curb chain must be at least 1/2" in width and lie flat

Hunter Performance Classes

Legal mouthpieces

Smooth round

Slow twist

Corkscrew

Single twisted wire

Double twisted wire

Straight bar or solid

Maximum 1 1/2" port

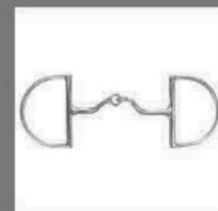
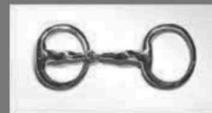

Hunter Performance Classes

Illegal Equipment Protective boots and leg wraps



Exception: boots or leg wraps are legal in open jumping

Resources

<http://www.avilaproshop.com>
<http://www.bitandbridleshop.com>
<http://www.davismanufacturing.com>
<http://www.greenrivertack.com>
<http://www.horsetackinternational.com>
<http://www.hought.com>
<http://www.kyhorse.com>
<http://www.rein-aid.com>
<http://www.tackranch.com>
<http://www.tackroominc.com>
<http://www.thinklikeahorse.org>

Hunter Performance Classes

Illegal Equipment
Draw reins



Hunter Performance Classes

Illegal Equipment
Mechanical hackamore



Hunter Performance Classes

Illegal mouthpieces

Cathedral bits

Donut bits

Prong bits

Rough or sharp edges

Square stock, metal wrapped

Polo bits

Hunter Performance Classes

Illegal Equipment

Martingales

(not allowed in flat classes or hunter hack)

